

# **ZX6** *Future Soilder System*

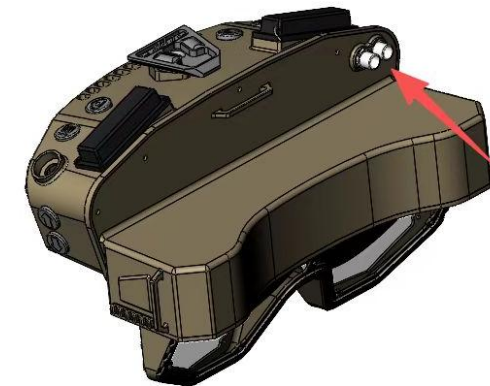

**ZX6 = Thermal Fusion Night Vision+FPV AR Glass+Target Locator+Anti-Drone Detector**

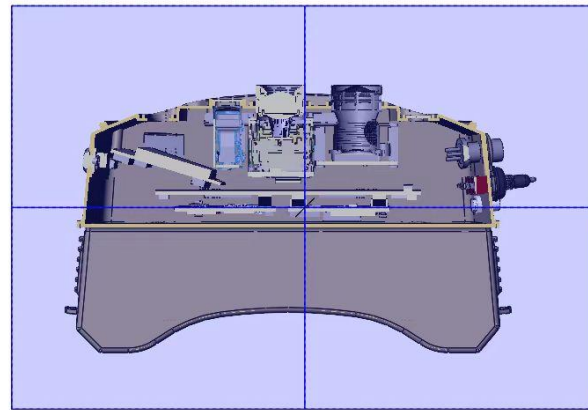

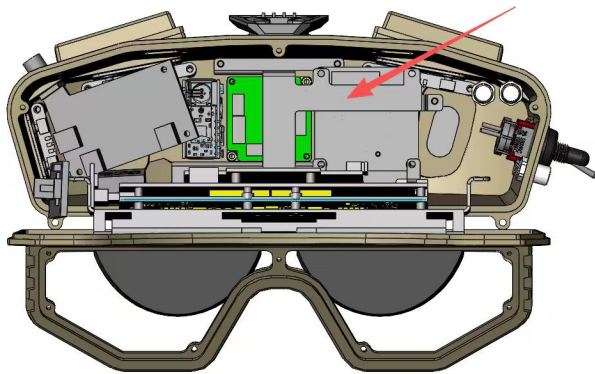
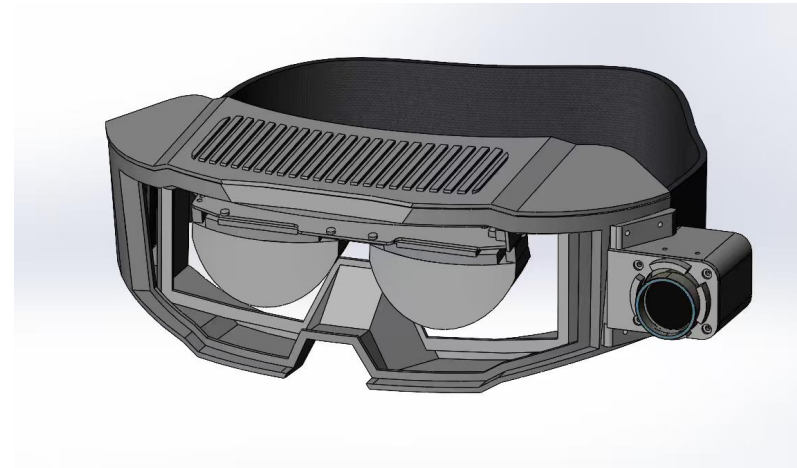
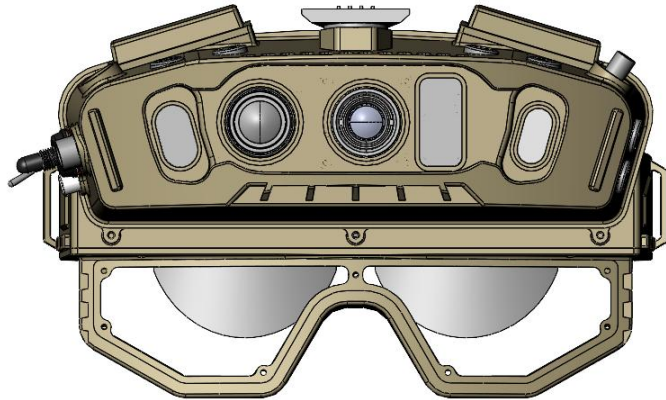

***What will the combat methods of  
future wars be like?***

***FPV War***

# Instruction

The ZX6 is a squad-level stereoscopic reconnaissance and combat system that surpasses the US military's IVAS virtual and augmented reality system.

It integrates AI intelligent recognition processors, high-definition thermal imaging, color night vision, laser rangefinding, drone communication, electronic compass, and AR near-eye display technology, enabling individual soldiers to achieve all-weather, multi-faceted, stereoscopic situational awareness and combat capabilities. Combined with reconnaissance drones, it can clearly locate and identify targets in darkness, fog, and complex environments.

Through its computing unit, the AR headset provides real-time overlay of 3D real-world maps, enemy and friendly force situational awareness, navigation, and combat orders, giving soldiers a clear view of the battlefield. It can initiate long-range swarm attacks and, when combined with a mortar coordination module, supports long-range direct and indirect fire. Combined with a thermal imaging sight, it enables "corner shooting" from behind cover. This fundamentally changes future individual soldier combat modes.

At the same time, it achieves squad and platoon-level data interconnection and real-time information sharing, ensuring seamless integration of command and combat. AI intelligence and automated combat reach a new level.

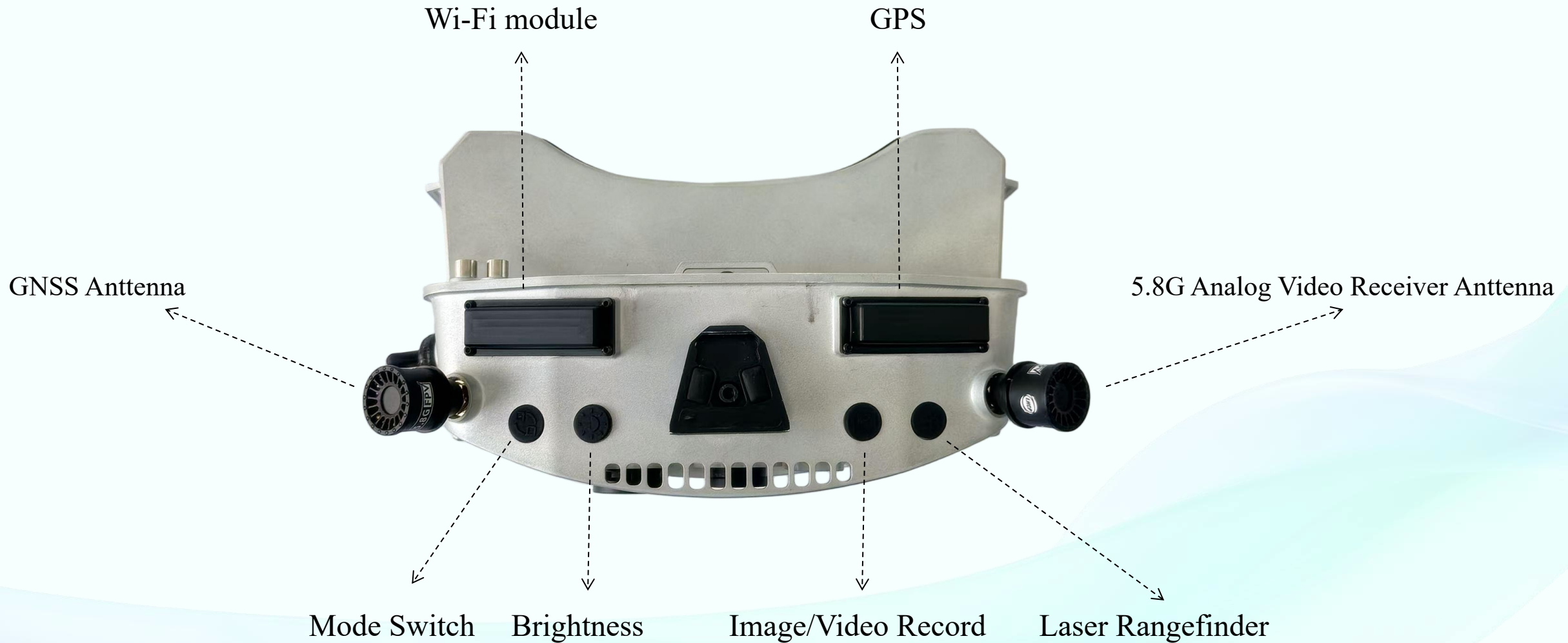

Image Mode: 1. Fusion1; 2. Fusion2; 3. Drone image input ; 4. Sight input; 5. Black hot; 6. White hot;  
7. Hot track; 8. Color night vision

# Characteristic & Specification

**Target Locator**

**AI Recognition,**

**Thermal-Visible Image Fusion Night Vision**

**Coloring Night Vision**

**Work with FPV and Drone**

**Built in 5.8G Video Receiver with Scan Function**

**Obtain the enemy's FPV video.**

**AR Display**

**Corner Shooting**

**Lightweight and Compact Design**



# Characteristic & Specification



## Specification

Item	Parameter
Model	ZX6
FOV	45°(diagonal)
Max Brightness	≥800nits
AR Display Quality	MTF≥0.4@30lp/mm
Display Resolution	1920x1080
IR Resolution	640x512@50Hz
Low Light Resolution	1920x1080@60Hz
Low Light Sensor	1/1.8 CMOS
Low Light Pixel Pitch	≥4um
Weight	≤500g
Overall Consumption	≤10W
IP Protection	IP67
Working Temperature	-40°C~+55°C
Min Working Illuminance	0.001lux
Video Input	Yes
WiFi	Yes
E-compass	Yes

# How to connect with FPV

## Analog Signal

Built-in 5.8G Analog Video Receiver

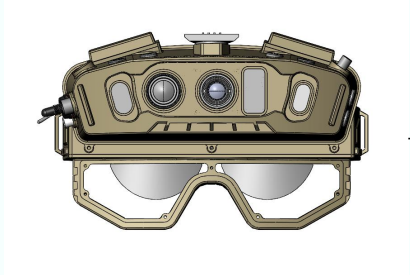

Wireless Connection

Get video from FPV

FPV  
Built-in 5.8G Analog Video Transmitter



2.4G Receiver



2.4G Signal Transmitter

Wireless Connection

Control FPV

## *Fly FPV with ZX6 Anti Jamming(optional)*



*The ZX6 integrates a 7G wireless analog image receiver, supporting FPV drone image display and completely revolutionizing the "soldier + drone" combat coordination model: soldiers no longer need to wear traditional FPV goggles when operating drones; they can simultaneously access both the drone's perspective and their own field of view through the ZX6, thereby improving pilot safety and situational awareness.*



*PS: Traditional drone jamming devices operate in the 20MHz to 6GHz frequency band; therefore, our 7GHz video transmission system will not be affected by interference.*

*Image from ZX6 when fly the drones*

## *Connected to HD Image Transmission Mini Drone*



*The ZX6 connects with a mini surveillance drone for covert reconnaissance.*

*Equipped with a high-definition camera, the mini drone enables covert reconnaissance with its compact size and low noise, providing a clear view of enemy movements.*

# How to connect with Drones

## Digital Signal

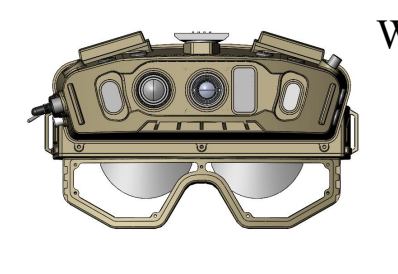

Wired Connected



Digital Video Receiver

Wireless Connection



Built-in Signal Receiver



Signal Transmitter

Wireless Connection

Control drone

## *Connected to the drone via fiber optic*



The ZX6 system features video input capabilities, allowing it to receive video directly from the fiber-optic drone ground station without the need for traditional VR glasses. This allows the operator to observe the surrounding environment using their peripheral vision while controlling the drone, significantly improving operational efficiency and effectively ensuring the operator's safety.

## *AR Display(Near-eye display)*

**Augmented Reality Display:** The information is displayed before your eyes through a free-form surface prism. suitable for night vision/bright light environments. Ensuring both clear readability and that it doesn't completely obstruct the real battlefield view, thus maintaining the soldier's awareness of the surroundings.



# AI Thermal Imaging Camera

Thermal imaging cameras allow soldiers to detect targets in challenging environments (such as those limited by smoke, fog, and vegetation).

The system is equipped with a high-performance artificial intelligence target recognition algorithm. Relying on deep learning and image feature extraction technology, it can automatically and accurately identify various tactical targets on the battlefield.

**Contour Enhancement:** By using algorithms to enhance the contours of targets in thermal imaging footage, key targets such as people and vehicles become clearer and easier to identify against complex backgrounds.

**Thermal-Visible Image Fusion:** By overcoming the physical limitations of single sensors, we can build more comprehensive, reliable, and intelligent environmental perception capabilities.



## Coloring Night Vision



**Night Image**



**ZX6 Image**

**Enhanced nighttime perception:** In nighttime infiltration and reconnaissance operations, high-definition color images allow for accurate identification of road obstacles, friendly forces' uniform colors, and the status of building doors and windows.

**Reduced fatigue:** The human eye is 30% more efficient at recognizing color images than black and white images. This can reduce eye strain during prolonged operations.

## Corner Shooting



The ZX6 connects to a thermal imaging scope, allowing soldiers to perform "corner shooting" from behind cover.

The ZX6 can be connected to an observation scope, allowing scouts to conduct reconnaissance without exposing themselves, thus improving the safety and efficiency of reconnaissance operations.

# M7L Thermal Sight with LRF



Customized  
special crosshair  
reticle

Model	<b>M7L</b>
Detector	VOx
Resolution	384x288/640x512
Pixel pitch	12um
Frame rate	50Hz
Lens	35mm/50mm
FOV	7.5°x5.7°/8.8°x7.0°
Laser range finder	10~1200m
Eye relief	18mm
Diopter adjustment	-5~+5
Display	0.39inch OLED
Zoom	1x/2x/4x/8x
PIP	Yes
WIFI	Yes
Operating time	≥9h
Working temperature	-40°C~+60°C
Weight	893g/967g
Shock resistace	1200G

## *Friendly and Enemy SITMAP(optional)*



Through an external display screen, the system can display in real time or dynamically the force deployment, positions, direction of movement, combat capabilities, and other relevant battlefield information of friendly forces and enemy forces.



**Electronic ompass:** It provides continuous and accurate directional guidance, helping soldiers quickly locate themselves, their teammates, targets, and key landmarks.



**Lightweight design:** The device weighs only 500 grams, so you won't feel a significant weight burden even after wearing it for extended periods.



**High protection level:** The IP67 protection rating allows the ZX6 system to be used in a variety of challenging weather conditions.



**Training simulation adaptability:** Supports integration with tactical training systems to conduct realistic training in simulated battlefield environments.

***THANKS FOR YOUR WATCHING***

The background features a dynamic, abstract design of flowing, translucent waves in shades of light blue and teal. The waves originate from the bottom right and curve upwards and to the left, creating a sense of movement and depth. The overall aesthetic is clean and modern.